

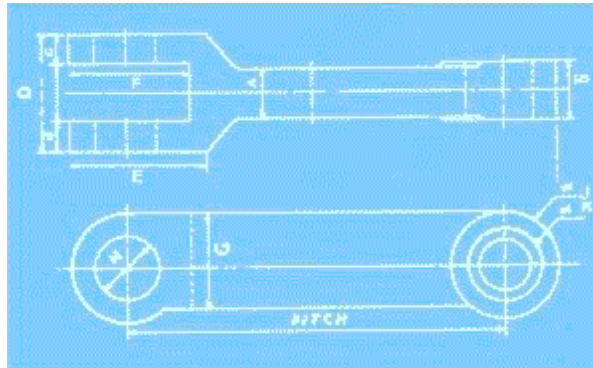

RACK CARRIER CHAINS



Detail of material

Link- Forged Steel

Pin-Bush=Medium Carbon Steel Heat Treated

Pitch	A	B	C	D	E	F	G	H	J	K Average	Ultimate Strength
229	28	35	18.5	72	83	76	56	35	70	41.75	60 Ton
200	19	28	13	55	76	70	46	26	62.5		40 Ton

The main Link of the chain is manufactured of forged steel. Pins and Bushes are manufactured of alloy steel with heat treated for longer life.

11,VASTA HOUSE,GR.FLOOR,JANMABOOMI MARG,
FORT ,MUMBAI-400001 ,INDIA.

TEL:91-22-22844307/22871995/22872449

FAX:91-22-22873597/22870770

E-mail:info@wiperdrive.com,WEB SITE:www.wiperdrive.com