

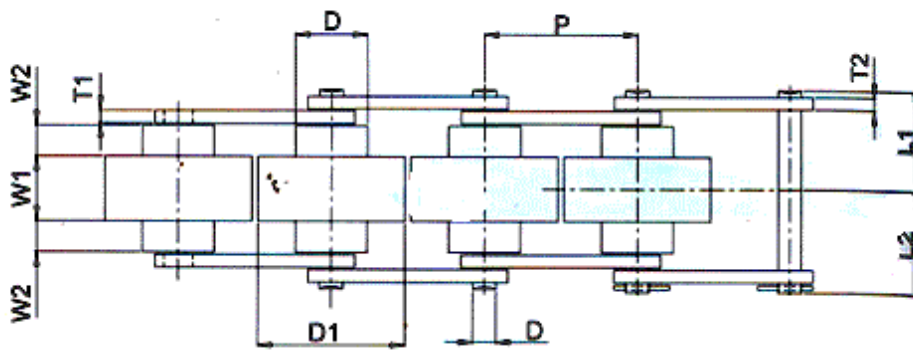

DOUBLE PLUS CHAIN

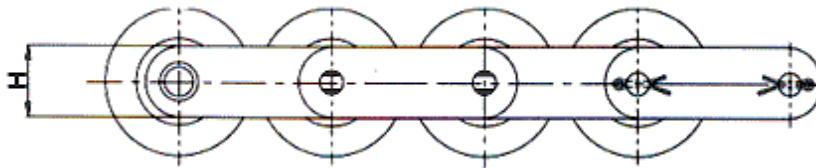

INTEL. REF.NO.	CHAIN NO.	PITCH (P)	(D)	(D1)	(W1)	(W2)	(T1)	(T2)	(H)	(D)	(L1)	(L2)	AVG. WEIGHT PER METER (KG)
C2040	A08A01 DP 01	25.40	15.88	24.60	10.30	5.70	1.50	1.50	11.6	3.97	15.30	16.50	1.00
C2050	A10201DP01	31.75	19.05	30.60	13.00	7.10	2.00	2.00	14.58	5.09	19.15	19.85	1.40
C2060H	A12Z010005	38.10	22.23	36.60	15.50	8.50	3.15	3.15	18.06	5.94	24.50	26.40	2.40

11, VASTA HOUSE, GR. FLOOR, JANMABOOMI MARG,
FORT, MUMBAI-400001, INDIA.

TEL: 91-22-22844307/22871995/22872449

FAX: 91-22-22873597/22870770

E-mail: info@wiperdrive.com, WEB SITE: www.wiperdrive.com