

TYPE AVT-3 PHASE GEARMOTOR DIMENSIONS TABLE

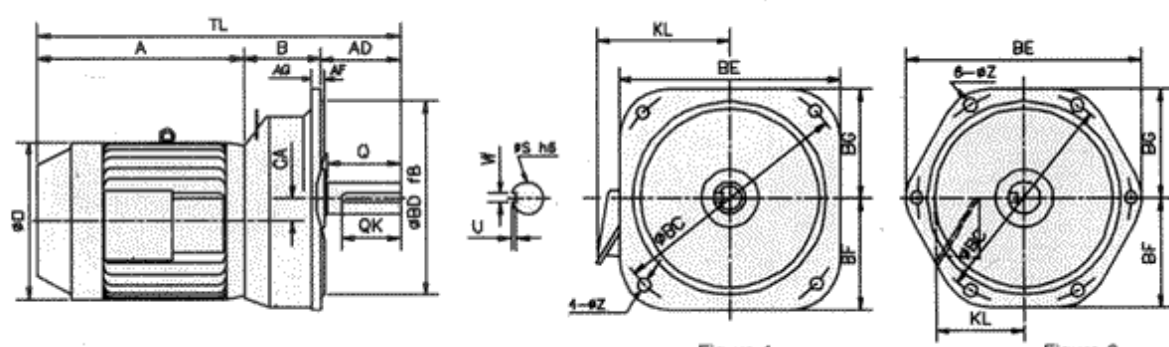

CLASS	MOTOR (KW)	RATIO	FRAME	DIMENSIONS													MASS (KG)									
				TL	A	AD	AF	AG	B	CAD	KL	FLANGE FIG	BC	BD	BE	BF		BG	Z	SHAFT-END Q	QKS	W	U			
S	0.4	1/5	AVTB5S																							
		1/10	AVTB10S	335	203	42	3	11	90	22	140	115	1	180	160	180	100	90	10	36	31	22	6	3.5		
		1/15	AVTB15S																							
		1/20	AVTB20S																							
		1/25	AVTC25S	343	203	42	3	12	98	26	140	115	1	225	180	210	115	105	12	36	31	24	8	4	14.2	
		1/30	AVTC30S																							
		1/45	AVTC45S																							
		1/50	AVTC50S	357	203	42	3	12	112	26	140	115	1	225	180	210	115	105	12	36	31	24	8	4	15.2	
		1/60	AVTC60S																							
		1/75	AVTC75S																							
		1/100	AVTD100S																							
		1/130	AVTD130S	391	203	66	3	16	122	33	140	115	1	270	230	260	130	130	15	58	53	32	10	5	27.2	
		1/150	AVTD150S																							
		1/200	AVTE200S	396	203	68	5	16	135	34	140	115	1	310	250	300	150	150	19	58	53	58	10	5	35.2	
		S	0.75	1/5	AVTC5S																					
1/10	AVTC10S			370	230	42	3	12	98	26	156	128	1	225	180	210	115	105	12	36	31	24	8	4	17.2	
1/15	AVTC15S																									
1/20	AVTC20S																									
1/25	AVTD25S			404	230	66	3	16	108	33	156	128	1	270	230	260	130	130	15	58	53	32	10	5	29.2	
1/30	AVTD30S																									
1/45	AVTD45S																									
1/50	AVTD50S			418	230	66	3	16	122	33	156	128	1	270	230	260	130	130	15	58	53	32	10	5	30.2	
1/60	AVTD60S																									
1/75	AVTD75S																									
1/100	AVTE100S																									
1/130	AVTE130S			431	230	68	5	16	135	34	156	128	1	310	250	300	150	150	19	58	53	38	10	5	38.7	
1/150	AVTE150S																									
1/200	AVTF200S			431	230	92	5	20	152	39	156	128	2	350	310	390	180	180	19	82	77	42	12	5	49.7	
S	1.5			1/5	AVTD5S																					
		1/10	AVTD10S	454	268	66	3	16	120	33	176	138	1	270	230	260	130	130	15	58	53	32	10	5	36	
		1/15	AVTD15S																							
		1/20	AVTD20S																							
		1/25	AVTE25S	465	268	68	5	16	129	34	176	138	1	310	250	300	150	150	19	58	53	38	10	5	44	
		1/30	AVTE30S																							
		1/45	AVTE45S																							
		1/50	AVTE50S	483	268	68	5	16	147	34	176	138	1	310	250	300	150	150	19	58	53	38	10	5	45.5	
		1/75	AVTE75S																							
		1/100	AVTF100S	521	268	92	5	20	161	42	176	138	2	350	350	390	180	180	19	82	77	42	12	5	56.5	
		1/130	AVTG130S																							
		1/150	AVTG150S	541	268	92	5	20	181	47	176	138	2	380	340	420	195	195	19	82	77	48	14	5	57.7	

TYPE AVT-3 PHASE GEARMOTOR DIMENSIONS TABLE

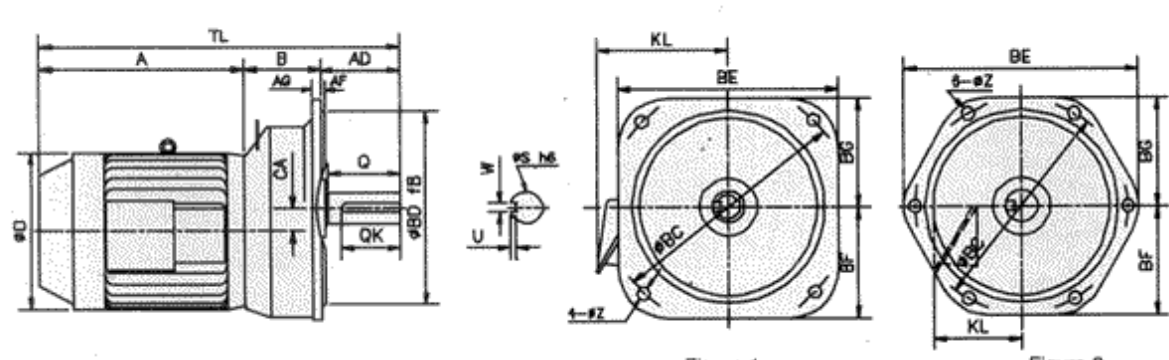

CLASS	MOTOR (KW)	RATIO	FRAME	DIMENSIONS													MASS (KG)										
				TL	A	AD	AF	AG	B	CAD	KL	FLANGE FIG	BC	BD	BE	BF		BG	Z	SHAFT-END Q	QKS	W	U				
S	2.2	1/5	AVTE5S																								
		1/10	AVTE10S	497	300	68	5	16	129	34	193	152	1	310	250	300	150	150	19	58	53	38	10	5	48		
		1/15	AVTE15S																								
		1/20	AVTE20S																								
		1/25	AVTF25S	532	300	92	5	20	140	42	193	152	2	350	310	390	180	180	19	82	77	42	12	5	58		
		1/30	AVTF30S																								
		1/45	AVTF45S																								
		1/50	AVTF50S	553	300	92	5	20	161	42	193	152	2	350	310	390	180	180	19	82	77	42	12	5	60.5		
		1/60	AVTF60S																								
		1/75	AVTG 75S																								
		1/100	AVTG100S	573	300	92	5	20	181	47	193	152	2	380	340	420	195	195	19	82	77	48	14	5	58.1		
		S	5.5	1/5	AVTF5S																						
				1/10	AVTF10S	560	325	92	5	20	143	42	218	170	2	350	310	390	180	180	19	82	77	42	12	5	70
				1/15	AVTF15S																						
				1/20	AVTF20S																						
1/25	AVTG25S			569	325	92	5	20	152	47	218	170	2	380	340	420	195	195	19	82	77	48	14	5	58.7		
1/30	AVTG30S																										
1/45	AVTG45S																										
1/50	AVTG50S			595	325	92	5	20	178	47	218	170	2	380	340	420	195	195	19	82	77	48	14	5	59.2		
1/60	AVTG60S																										
1/75	AVTF100S																										
1/10	AVTF130S			605	362	92	5	20	151	42	260	190	2	350	310	390	180	180	19	82	77	42	12	5	91		
1/15	AVTF150S																										
1/20	AVTG20S			617	362	92	5	20	163	52	260	190	2	380	340	420	195	195	19	82	77	48	14	5	109		
S	7.5			1/5	AVTD5S																						
				1/10	AVTD10S	660	400	92	5	20	168	52	260	190	2	380	340	420	195	195	19	82	77	48	14	5	122
		1/15	AVTD15S																								