

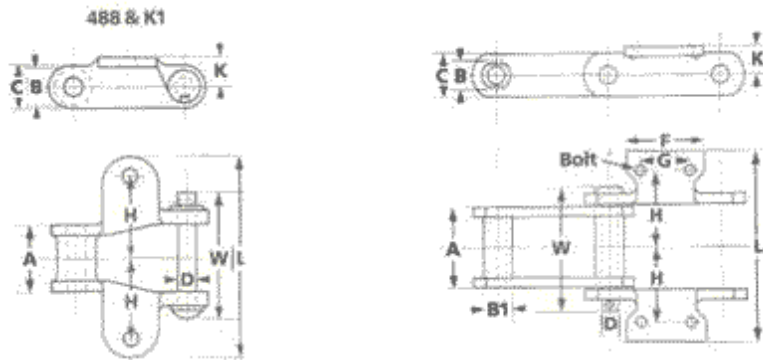

SUGAR ELEVATOR CHAIN



CHAIN NO	PITCH NO	ALLOWABLE CHAIN PULL LB.FT	BREAKING LOAD		WEIGHT		A	B	B	C	D	E	W	F	G	H	K	L	BOLT DIA
			LB	KG	PLAIN LB/FT	KATTS LB/FT													
458	261	1.800	11.000	4994	3.5	45	156	875	-	1.00	438	75	106	1438	-	1906	.688	4.75	313
C131	307	3220	27.500	12.485	55	75	200	125	1438	150	625	1.125	3625	2625	150	2062	1.00	525	50
SS1028	400	63000	40.000	18150	59	90	2875	100	-	150	625	200	4344	2813	1.75	2656	1.00	650	375
C123	600	10.000	60.000	27240	145	17.7	4375	1718	1.906	2000	100	2875	650	400	2.75	375	1.25	900	50

11, VASTA HOUSE, GR. FLOOR, JANMABOOMI MARG,

FORT, MUMBAI-400001, INDIA.

TEL: 91-22-22844307/22871995/22872449

FAX: 91-22-22873597/22870770

E-mail: info@wiperdrive.com, WEB SITE: www.wiperdrive.com