

HEAVY TIMING PULLEY

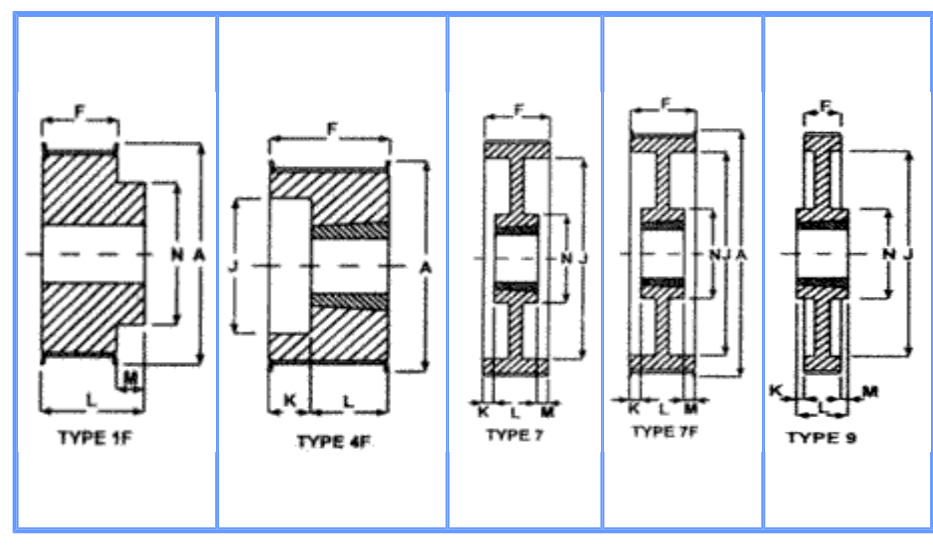

H100-3/4"(19 MM)AND 1"(25MM)WIDE BELTS

PULLEY DESIGNATION	PITCH DIAM	NO.OF TEETH	BUSH NO.	MAX. BORE METRIC	MAX. BORE INCH	PULLEY TYPE	A	F	J	K	L	M	N
18H100	72.77	18	1210	32	1	4F	79	32	51	7	25	-	-
19H100	76.81	19	1210	32	1	4F	83	32	51	7	25	-	-
20H100	80.85	20	1210	32	1	4F	86	32	57	7	25	-	-
21H100	84.89	21	1210	32	1	4F	90	32	52	7	25	-	-
22H100	88.94	22	1210	32	1	4F	95	32	52	7	25	-	-
23H100	92.98	23	1610	42	1	4F	98	32	64	7	25	-	-
24H100	97.02	24	1610	42	1	4F	103	32	64	7	25	-	-
25H100	101.06	25	1610	42	1	4F	106	32	64	7	25	-	-
26H100	105.11	26	1610	42	1	4F	111	32	70	7	25	-	-
27H100	109.15	27	1610	42	1	4F	114	32	76	7	25	-	-
28H100	113.19	28	1610	42	1	4F	119	32	81	7	25	-	-
30H100	121.28	30	1610	42	1	4F	127	32	89	7	25	-	-
32H100	129.36	32	1610	42	1	4F	135	32	95	7	25	-	-
36H100	145.53	36	1610	42	1	4F	151	32	111	7	25	-	-
40H100	161.70	40	1610	50	2	7F	168	32	130	7	25	-	-
48H100	194.04	48	2012	50	2	9	200	32	162	0	32	0	111
60H100	242.55	60	2012	50	2	9	-	32	210	0	32	0	111
72H100	291.06	72	2012	50	2	9	-	32	257	0	32	0	111
84H100	339.57	84	2012	50	2	9	-	32	306	0	32	0	111
96H100	388.08	96	2517	60	2	9	-	32	354	6.5	45	6.5	124
120H100	485.10	120	2517	60	2	9	-	32	451	6.5	45	6.5	124
156H100	630.64	156	2517	60	2	9	-	32	597	6.5	45	6.5	124

H150-112/2"(38MM) WIDE BELTS

PULLEY DESIGNATION	PITCH DIAM	NO.OF TEETH	BUSH NO.	MAXBORE MET.	MAXBORE INCH	PULLEY TYPE	A	F	J	K	L	M	N
18H100	72.77	18	1210	32	1	4F	79	45	51	20	25	-	-
19H100	76.81	19	1210	32	1	4F	83	45	51	20	25	-	-
20H150	80.85	20	1210	32	1	4F	86	45	57	20	25	-	-
21H150	84.89	21	1210	32	1	4F	90	45	59	20	25	-	-
22H150	88.94	22	1210	32	1	4F	95	45	59	20	25	-	-
23H150	92.98	23	1610	42	1	4F	98	45	64	20	25	-	-
24H150	97.02	24	1610	42	1	4F	103	45	64	20	25	-	-
25H150	101.06	25	1610	42	1	4F	106	45	64	20	25	-	-
26H150	105.11	26	1610	42	1	4F	111	45	73	20	25	-	-
27H150	109.151	27	1610	42	1	4F	114	45	76	20	25	-	-
28H150	113.19	28	1610	42	1	4F	119	5	76	20	25	-	-
30H150	121.28	30	1610	42	1	4F	127	5	89	20	25	-	-
32H150	129.36	32	1610	42	1	4F	135	45	95	20	25	-	-
36H150	145.53	36	1610	42	1	4F	151	45	111	20	25	-	-
40H150	161.70	40	1610	50	2	7F	168	45	130	20	25	-	-
48H150	194.04	48	2012	50	2	7	200	45	162	6.5	32	6.5	111
60H150	242.55	60	2012	50	2	7	-	48	210	8	32	8	111
72H150	291.06	72	2012	50	2	7	-	48	257	8	32	8	111
84H150	339.57	84	2012	50	2	7	-	48	306	8	32	8	111
96H150	388.08	96	2517	60	2	7	-	48	354	1.5	45	1.5	124
120H150	485.10	120	2517	60	2	7	-	48	451	1.5	45	1.5	124
156H150	630.64	156	2517	60	2	7	-	48	597	1.5	45	1.5	146

H200-2(51MM)WIDE BELTS

PULLEY DESIGNATION	PITCH DIAM	NO.OF TEETH	BUSH NO.	MAX. BORE METRIC	MAX. BORE INCH	PULLEY TYPE	A	F	J	K	L	M	N
18H200	72.77	18	PILOT BORE ONLY	42	-	1F	79	58	-	-	58	0	-
19H200	76.81	19	PILOT BORE ONLY	42	-	1F	83	58	-	-	58	0	-
20H200	80.85	20	1610	42	-	1F	86	58	-	-	58	0	-
21H200	84.89	21	1610	42	1	4F	90	58	59	33	25	-	-
22H200	88.94	22	1610	42	1	4F	95	58	64	33	25	-	-
23H200	92.98	23	1610	42	1	4F	98	58	64	33	25	-	-
24H200	97.02	24	1610	42	1	4F	103	58	64	33	25	-	-
25H200	101.06	25	1610	42	1	4F	106	58	64	33	25	-	-
26H200	105.11	26	1610	42	1	4F	111	58	70	33	25	-	-
27H200	109.151	27	1610	42	1	4F	114	58	76	33	25	-	-
28H200	113.19	28	1610	42	1	4F	119	58	76	33	25	-	-
30H200	121.28	30	1610	42	1	4F	127	58	89	33	25	-	-
32H200	129.36	32	2012	50	2	4F	135	58	97	26	32	-	-
36H200	145.53	36	2012	50	2	4F	151	58	111	26	32	-	-
40H200	161.70	40	2012	50	2	4F	168	58	130	26	32	-	-
48H200	194.04	48	2517	60	2	7F	200	58	162	6.5	45	6.5	124
60H200	242.55	60	2517	60	2	7	-	59	210	7	45	7	124
72H200	291.06	72	2517	60	2	7	-	59	257	7	45	7	124
84H200	339.57	84	2517	60	2	7	-	59	306	7	45	7	124
96H200	388.08	96	2517	60	2	7	-	59	354	7	45	7	124
120H200	485.10	120	2517	60	2	7	-	59	451	7	45	7	146
156H200	630.64	156	3030	75	3	9	-	59	597	8.5	76	8.5	146

H300-3"(76MM) WIDE BELTS

PULLEY DESIGNATION	PITCH DIAM	NO.OF TEETH	BUSH NO.	MAX. BORE METRIC	MAX. BORE INCH	PULLEY TYPE	A	F	J	K	L	M	N
18H300	72.77	18	PILOT BORE ONLY	42	-	1F	79	84	-	-	84	0	-
19H300	76.81	19	BORE ONLY	42	-	1F	83	84	-	-	84	0	-
20H300	80.85	20	ONLY	42	-	1F	86	84	-	-	84	0	-
21H300	84.89	21	1615	42	1	4F	90	84	60	46	38	-	-
22H300	88.94	22	1615	42	1	4F	95	84	64	46	38	-	-
23H300	92.98	23	1615	42	1	4F	98	84	64	46	38	-	-
24H300	97.02	24	1615	42	1	4F	103	84	60	46	38	-	-
25H300	101.06	25	1615	42	1	4F	106	84	64	46	38	-	-
26H300	105.11	26	1615	42	1	4F	111	84	70	46	38	-	-
27H300	109.15	27	2012	50	2	4F	114	84	78.5	52	32	-	-
28H300	113.19	28	2012	50	2	4F	119	84	78.5	52	32	-	-
30H300	121.28	30	2012	50	2	4F	127	84	89	52	32	-	-
32H300	129.36	32	2517	60	2	4F	135	84	97	39	45	-	-
36H300	145.53	36	2517	60	2	4F	151	84	111	39	45	-	-
40H300	161.70	40	2517	60	2	4F	168	84	130	39	45	-	-
48H300	194.04	48	2517	60	2	7F	200	84	162	19.5	45	19.5	124
60H300	242.55	60	2517	60	2	7	-	86	210	20.5	45	20.5	124
72H300	291.06	72	2517	60	2	7	-	86	257	20.5	45	20.5	124
84H300	339.57	84	2517	60	2	7	-	86	306	20.5	45	20.5	124
96H300	388.08	96	3030	75	3	7	-	86	354	5	76	5	146
120H300	485.10	120	3030	75	3	7	-	86	451	5	76	5	146
156H300	630.64	156	3030	75	3	7	-	86	597	5	76	5	178

DIMENSIONS IN MILIMETERS UNLESS OTHERWISE INDICATED .PULLEY TYPE 'F' INDICATES PULLEY IS WITH FLANGES.